



MES Operational Manual

 Operators should read and understand this manual and all warning Labels on power pallet truck before using the truck

CONTENT

1. TECHNICAL FEATURES.....	1
2. ADHESIVE.....	2
3. ADVISES.....	3
4. WORKING NORMS FOR THE OPERATOR.....	3
5. RECHARGE OF BATTERY	4
6. DAILY MAINTENANCE.....	4
7. PROGRAMMED MAINTENANCE.....	5

1. TECHNICAL FEATURES

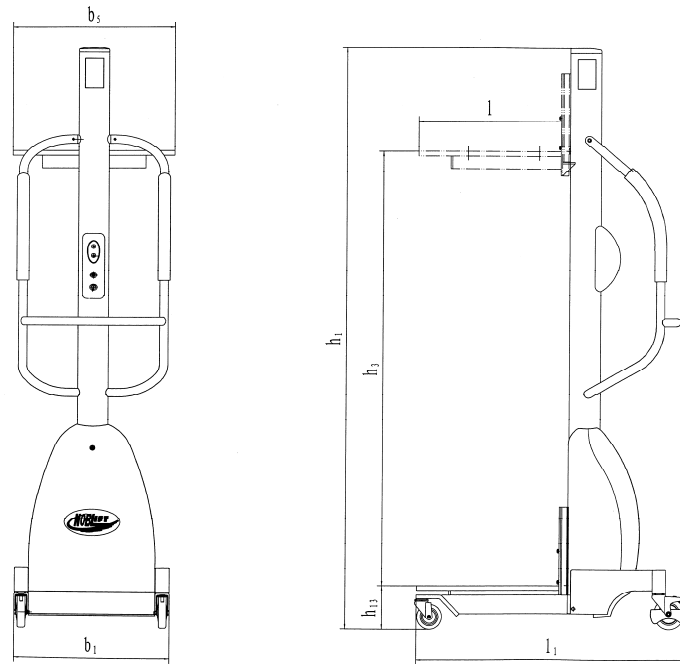

Identification	Manufacturer's type designation		MES15	MES150A	MES150B	MES150/801
	Type of operation :hand , pedestrian, standing, seated, order-picker		hand			
	Load Capacity / rated load	Q kg	150			
Weights	Service weight	kg	58	56	54	60
Wheels, Chassis	Tyres:solid ,rubber,superelastic,pne		polyurethane			
	Tyre size,front	mm	Φ75x32			
	Tyre size,rear	mm	Φ100x32			
	Wheels, number		4			
Basic Dimensions	Lowered mast height	h ₁ mm	1958			
	Lift height	h ₃ mm	1420	1435	1440	1400
	Lowered height	h ₁₃ mm	130	115	110	65
	Overall length	l ₁ mm	880	865	920	920
	Overall width	b ₁ mm	520	500	500	801
	Fork dimensions	l mm	460	445	500	500
	Width over forks	b ₅ mm	520	400(Φ40x2)	Φ60	650
Performance Data	Lift speed, laden/unladen	mm/s	67/82			
	Lowering speed,laden/unladen	mm/s	96/89			
E-Motor	Lift motor rating	W	90			
	Battery acc.to BS,no		NO			
	Battery voltage,nominal capacity	V/Ah	2X12/7			



2. ADHESIVE

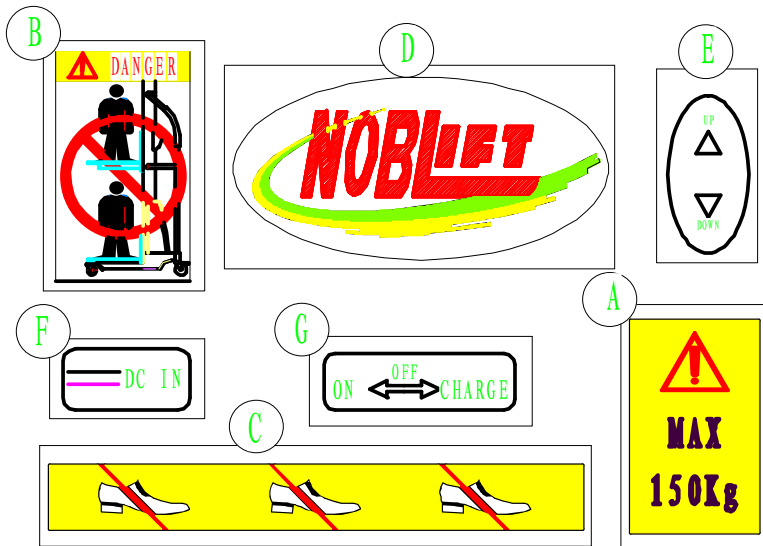
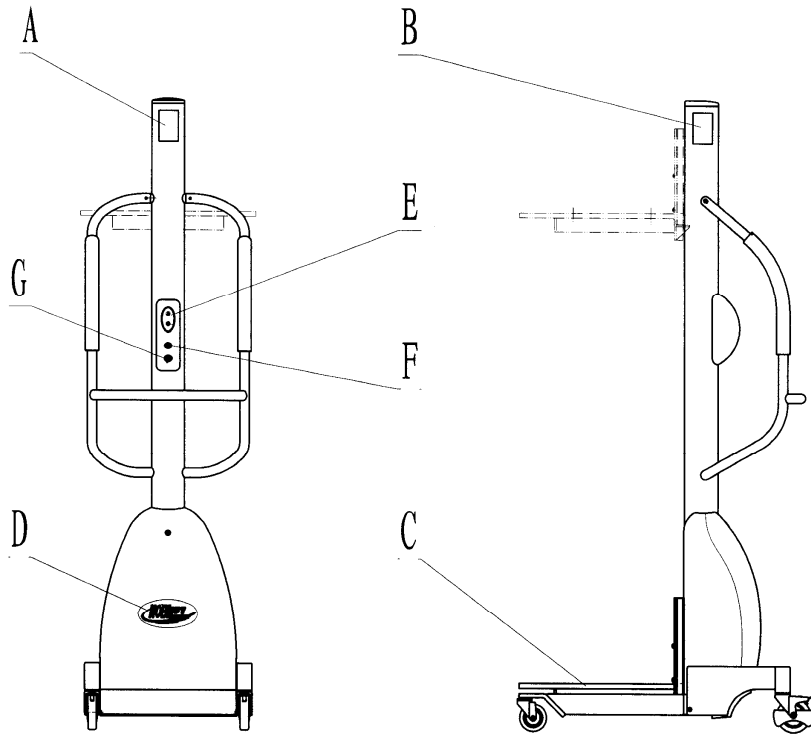

REMARKS:

- A: Capacity limitation .B: Warning. C: Danger! “watch your step”.
 D: Trademark E: Switch F: Recharging
 G: Power

3. ADVISES

- 3.1 Read this instruction carefully before using the stacker. If necessary, please call our technical people for assistance.
- 3.2 Move the stacker always keeping the forks at the lowest position while no loading on the forks. Pay attention not to hurt anybody around your working area.
- 3.3 People are forbidden to stand on the forks of the stacker. Do not leave the stacker on the working place after used. The load capacity of the stacker depends on the lifting height and the position of the load center, please refer to the relative technical features in this instruction.
- 3.4 The adhesive label on the stacker must be always legible. Do not use the stacker for purpose except lifting or lowering load.
- 3.5 Do not make casual repair. If repaired by unprofessional people, the safety modulus of the machine could be altered. In case damage happens, repair it in the local place according to the instruction or contact to us.
- 3.6 Carry out all the work and maintenance according to the norms after using it.

4. WORKING NORMS FOR THE OPERATOR

Do not worry about how to operating this stacker, the characteristic of this stacker is facility and easy to operate.

4.1 The two function of the brakes

The rear wheels are equipped with brakes which with two functions, it can control the moving of forward and backward effectively。 Step the pedal of the brake backward, the stacker will be braked. Step the pedal of the brake forward, the stacker will travel normally. The stacker should be braked under the condition as following: A, stop at the slope; B, during charging; C, when loading; D, leave unused.

4.2 The forward/backward/swivel of the stacker

Open the brake of the rear wheels, leave the two wheels at the state which can swivel freely. Take hold of the armrest, push the stacker ahead, the stacker can move ahead. In the same way, pull the stacker backward, the stacker will fall back. We use universal wheels on this truck, so it's very easy to swivel and swivel into any direction. It's only need a small space because it can be freely swiveled at the original position. If one of the brake is locked, the stacker will be swiveled on an even keel according to the centre of a circle.

4.3 Lifting and lowering of the forks

Press the button of power to "ON", then press the " ◀ " or " ▶ " to control the lifting and lowering of the stacker. (Attention: Before lifting or lowering the forks with load on the forks, please lock the rear wheels of the stacker to avoid moving of the stacker during lowering and lowering.)

4.4 Load of the stacker

According to the deferent goods, this stacker can use the three kinds of shelves as double forks, single fork, and platform. The ways of how to use these shelves are as follows:

A. Double forks (be fitted for lifting the common load)

- (1) Drive close to the load.
- (2) Lift the forks below the load.
- (3) Drive forward, bringing the forks under the load.
- (4) Lift the load to get the load.
- (5) Back the stacker with the load to make the descent if possible.
- (6) Lower the load slowly.

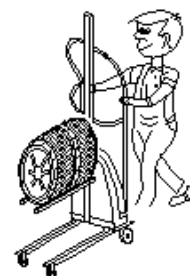

B. Single fork (be fitted for lifting the cylindraceous load)

- (1) Drive close to the load.
- (2) Drive the fork to the centre of the circle of the load.
- (3) Drive forward, extend the fork inside the cylinder.
- (4) Lift the load to get the load.
- (5) Back the stacker with the load to make the descent if possible.
- (6) Lower the load slowly.

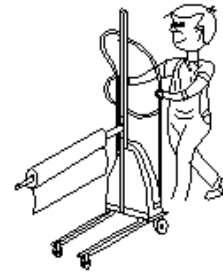

C. Platform (be fitted for the lifting the load with small volume)

- (1) Drive close to the load.
- (2) Lift the platform to a proper position (be convenient for people to stack the goods)
- (3) Transfer the goods to the platform artificially.
- (4) Lower the platform.

Attention: If possible, the platform with load can be lifted as the double forks.



4.5 The steps of unloading the goods

A. Double forks/ single forks

- (1) Get close to the position.
- (2) Lift the load up to the desired height position.
- (3) Advance slowly to bring the load to the proper position.
- (4) Lower the load to make the bottom of the forks on the shelf.
- (5) After unloaded, back the forks slowly.

B. Platform

- (1) Drive the stacker with load to the destination, and lock the rear wheels.
- (2) Lift the platform to a proper height for people to unload it.
- (3) Unloading.

5. RECHARGE OF BATTERY

The batteries of the stacker must be recharged with a constant continuity, and the recharging should be very timely.

When recharging, switch off the power. Connect the charger to the power supply, and insert the plug of the charger into the recharging faucet of the stacker, press the switch of charger, recharging will begin.

When recharging is over, the charger will stop automatically.

6. DAILY MAINTENANCE

The daily maintenance is a responsibility of the operator of the stacker. The main functions that must be checked are as follows:

1	Check the retarder of the motor.
2	Check the forks.
3	Check the swivel wheel.
4	Check the transmission belt.
5	Check the charger.

7. PROGRAMMED MAINTENANCE

In the following we show a table in which there are some tips about the programmed maintenance done by the authorized operators.

Before starting the maintenance you have to:

1. Put the stacker on an even and solid surface.
2. Brake the both rear wheels.

1	Check electrical systems, cleaning with air or with a brush and special detergent
2	Check the connections of the conductors.
3	Check and clean the driving-wheel group.
4	Check the wear of rollers and wheels.
5	Check movements and wears between masts and rollers with bearings.
6	Check and tighten all the screws and nuts.
7	Complete greasing of the stacker, bearings and sliding masts.